

- 1
- 2
- 3
- 4
- 5
- 6
- 7
- 8
- 9
- 10**
- 11
- 12
- 13
- 14
- 15
- RH

MATERIAL

Glass-fibre reinforced polyamide based (PA) technopolymer, black colour, matte finish.

STANDARD EXECUTIONS

- **TTB-A**: zinc-plated steel M10 screw, nut and washer.
- **TTB-SST**: AISI 304 stainless steel M10 screw, nut and washer.

FEATURES

Maximum tightening torque for screw assembly 35 Nm.

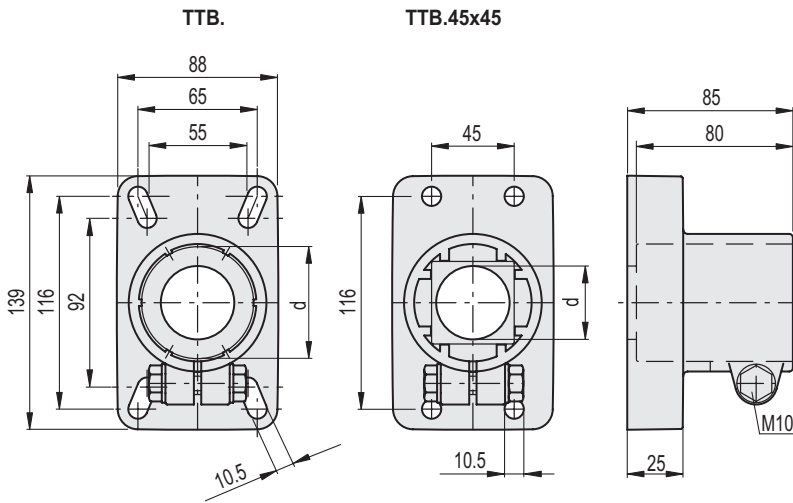

Conversion Table	
1 mm = 0.039 inch	
d	
mm	inch
42.4	1.67
48.3	1.90
50.8	2.00
60.3	2.37
45	1.77

TTB-A

METRIC

Code	Description	d Tube (mm)	d Tube (BSP/GAS)	d Tube (inch)	⚖
419768	TTB.42-A	42.4	1"1/4	-	345
419766	TTB.48-A	48.3	1"1/2	-	340
419772	TTB.50-A	50.8	-	2"	337
419764	TTB.60-A	60.3	2"	-	335
419770	TTB.45x45-A	45	-	-	340

TTB-SST

INOX STAINLESS STEEL METRIC

Code	Description	d Tube (mm)	d Tube (BSP/GAS)	d Tube (inch)	⚖
419769	TTB.42-SST	42.4	1"1/4	-	345
419767	TTB.48-SST	48.3	1"1/2	-	340
419773	TTB.50-SST	50.8	-	2"	337
419765	TTB.60-SST	60.3	2"	-	335
419771	TTB.45x45-SST	45	-	-	340